

The Novoflex Castel-M Focusing Rail



Robert Thompson



Novoflex Castel-M Focusing Rail



The Castel-M focusing rail with the Q=Mount, which can be rotated by loosening the hexagonal screw to accommodate different lenses with tripod collars and various Arca Swiss plates.

(Preceding page)

Phalaenopsis Orchid

A total of 45 images were used to complete the stack for this composite image of the lip and column.

INTRODUCTION

Since the evolution of digital photography, there have been many new and innovative products that have appeared in the photographic sector. The design of specialised accessories is one aspect that has seen many changes, with new equipment appearing frequently. Software development has also undergone considerable change. It is now possible with a few clicks of the mouse, to overcome many of the time-consuming processes and issues that were once challenging a few years ago. One of the biggest advances in macro photography is the ability to extend depth of field by combining individual images

using specialist equipment and software to capture subjects in ways that would have been almost impossible to achieve pre-digital.

In today's digital age, there are many companies both recent and established that specialise in the design and manufacture of a wide range of equipment for the photography industry. One of those companies with a worldwide reputation for quality and precision is Novoflex. They are a highly respected company based in Memmingen, Germany. Founded in 1948, it has a long-established reputation and is synonymous with innovation and the manufacture of

precision quality equipment for the photographic industry. Its well known trademark being, 'THE BEAUTY OF ENGINEERING'. As a successful company, they have designed and developed many unique products, particularly in the field of macro photography, where they have exceptional expertise. The Castel-M is the latest addition to their extensive macro line-up of specialist-focusing rails. The design is unique and has been developed specifically for those photographers engaged in macro photography, especially those that routinely focus stack at magnifications above 1:1 (life-size) up to reproduction ratios of 5:1.

In macro photography there are many challenges to overcome. Depth of field is one of the biggest that photographers have to contend with. As magnification increases, depth of field decreases, making it difficult to maintain sharp focus throughout the entire subject. Before the digital revolution, it was common practice to shoot at smaller apertures, for example, $f/16$, to maximise the zone of sharpness. The downside of this approach however leads to diffraction producing an image which can appear lacking in contrast and reduced sharpness. Working at magnifications above 1:1 creates additional challenges. The risk of

Woodland Crocus Crocus tommasinianus A 2X magnification of the stamens of this attractive woodland flower. A total of 47 images used to complete the final composite image.

vibration, or movement of the camera can compromise the final result. Reduced depth of field at higher magnifications makes it more challenging to achieve





Common Grey Disco Fungus Mollisia cinerea These tiny discs are around 1-1.5mm in size. The Castel-M is ideal for photographing small subjects when focus stacking is required.

consistently acceptable results, especially when photographing outdoors. Equipment needs to be designed and manufactured to the highest standards to alleviate all these difficulties. Most automated macro lenses generally do not extend beyond 1:1. There are a few manual lenses that exceed 1:1, such as, the Laowa 100mm $f/2.8$, an Ultra Macro lens with a maximum magnification of 2X. Some other specialised macros include the Laowa 25mm $f/2.8$ 2.5X-5X and the Canon MP-E65 $f/2.8$ 1X-5X. All of these lenses are ideally suited to the Castel-M rail. Stability of the setup is another important factor to consider especially when focus stacking at higher reproduction ratios. Having a sturdy tripod and solid head with no creep is essential

if you want to achieve continuity in your results.

FIRST IMPRESSIONS

Having owned and reviewed other rails from the Novoflex range. I was delighted when given the opportunity to test the prototype of their latest all-manual focusing rail. Like all of their products, it is beautifully engineered and finished to an extremely high standard. It also bears the typical Novoflex colour branding which is present in all of their equipment creating a connection and uniformity between all of their products. The rail itself is not large or too heavy, but feels robust and nicely balanced in the hand, each part connected with precision and accuracy. Another typical Novoflex feature common

on all of their rails is the elongated Arca Swiss dovetail mount, which allows you to position the rail by hand to where you want focus to commence. You can also attach the Castel-M to a second rail for precise placement, or when working at higher magnifications. A second rail can also be used horizontally to create a cross slide setup when the lens to subject distance is very close. It makes it easier to make fine adjustments on that plane. The rail and the large focus wheel have laser-engraved scaling to assist the photographer with maintaining precise stepping distances between images. The rail comes standard with the screw retained Q=Mount.

The Castel-M's design is unique and differs from the typical universal approach adopted by most equipment manufacturers. It's another example of Novoflex's ability to push the boundaries by creating a rail that makes all of the calculations for you in a precise and systematic way. No need to worry about stepping distances and focus overlap, leaving you to concentrate completely on the subject and produce more accurate, consistent results every time. The Castel-M also bridges the all-important gap between conventional rail designs such as the Castel Q, and XQII and high-end electronic focusing rails like the Castel Micro, offering a medium-priced alternative to their motorised equivalent.

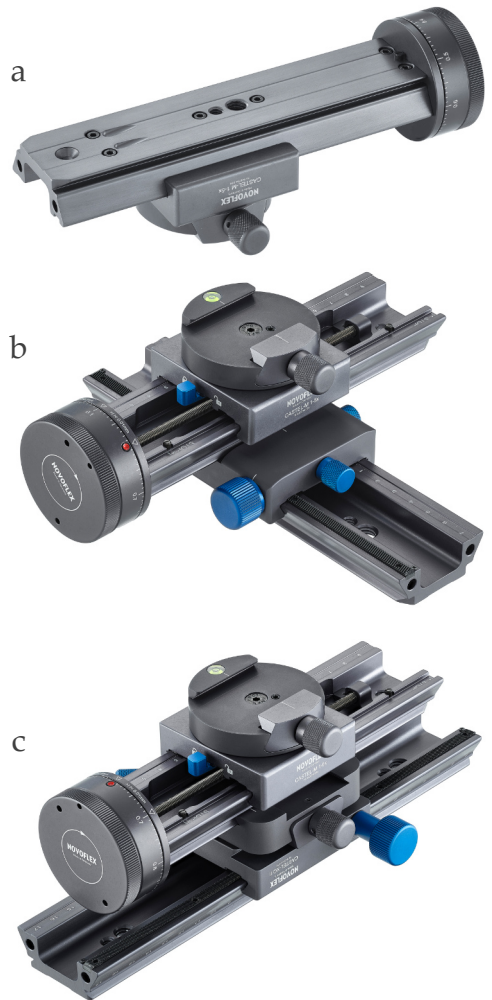

(a) The underside of elongated dovetail Arca Swiss mount which makes it much easier to place the rail in the correct position without having to constantly adjust the tripod.

(b) The Castel Q being used as a second rail for setting up cross slide two-dimensional focusing when working at very close distances.

(c) The Castel-M with the Castel XQ II being used as a second rail to facilitate accurate position when working at high reproduction ratios.

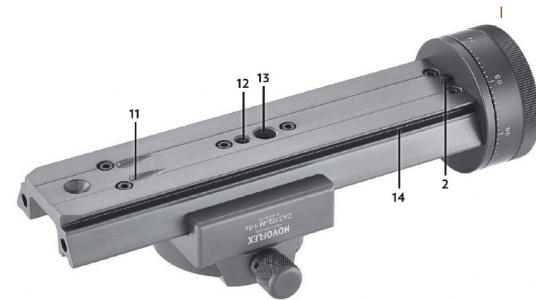
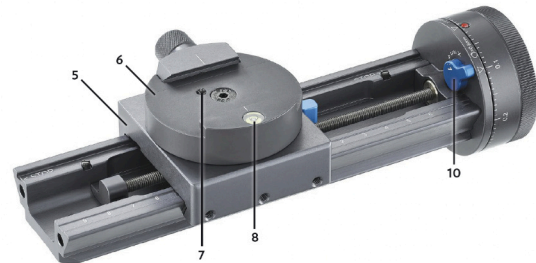
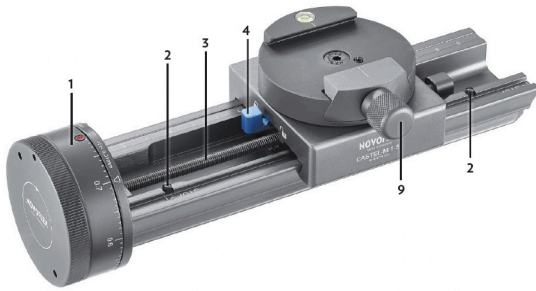

GLOSSARY OF TERMS

- | | |
|----|---------------------------------------|
| 1 | Focus wheel with length scaling |
| 2 | Stop screws 3x |
| 3 | Spindle |
| 4 | Locking lever spindle |
| 5 | Sliding block |
| 6 | Quick release unit Q=Mount type ARCA |
| 7 | Safety pin on quick release unit |
| 8 | Spirit level |
| 9 | Clamping screw Q=Mount |
| 10 | Increment selector lever (5 settings) |
| 11 | Milling cutout for safety pin |
| 12 | Tripod Mount 1/4 in-20 |
| 13 | Tripod Mount 3/8 in-16 |
| 14 | Dovetail guide type ARCA |

The various component parts of the Castel-M focusing rail.

RAIL DESCRIPTION

At the heart of the rail is a high-precision spindle which drives the sliding block forward by rotating the rear focus wheel. The spindle's low thread pitch means the camera assembly can be advanced forward in very small, even incremental steps making it ideal for focus stacking at higher magnifications. The travel, or stepping distance is determined by the setting on the

increment selector. One of the unique features of this specialised rail is its click-stop pre-sets. The focus wheel when rotated always locks into place after each pre-set distance. An image is captured at each click stop until the subject's range of focus is completed. There are five incremental settings which can be selected via the blue-coloured increment selector switch situated on the inside of the focus wheel. These incremental distances have been optimised for a 35mm full-frame sensor calculated at $f/4$ on the lens to minimise the onset of diffraction and to ensure a sufficient overlap of each image, which is necessary for the focus stacking software to produce the completed





(preceding page) *Common Bonnet Mycena galericulata*

These tiny bonnets were approximately 4cm high. I wanted to keep the background as shallow as possible and used a wide aperture. The rails is ideal in these situations. A total of 25 images were used to create the composite photograph.

(a)

Top image showing the increment selector lever, which you set to select the stepping distance.

(b)

Laser-engraved scale on the focus wheel which you can use manually to advance the camera assembly between shots.

composite photo. Reproduction ratios from 2:1 up to 5:1 are possible depending on the magnification chosen with the increment selector lever. The appropriate stepping distance is then adjusted to the correct amount depending on what setting has been chosen. When the increment selector is set to X the focus wheel's click stop is deactivated and it can be rotated freely.

There is a laser-engraved scale on the focus wheel which can be used to move the camera at precise distances when an all manual approach is required. One full clockwise rotation of the wheel advances the sliding block forward by 0.8mm. The engraved division marks on the focus wheel scale correspond to 0.01mm movement of the sliding block. A red lacquered dot provides a starting point for all movements and the front of the focus wheel has circular clockwise direction indicator.

The sliding block incorporates the Q=Mount quick-release unit with an integrated spirit level which can be rotated by loosening the central screw of the plate and moved to the preferred angle. The clamping screw will now be at the side or front of the base depending on the position selected. The different positions facilitate tripod collars on lenses and clamping plates attached to the camera base or lens. When rotating the Q=Mount a raised element on the base ensures precise alignment in a parallel or transverse



a



b



c

How to adjust and rotate the Q=Base when using different lenses with tripod collars or clamping Arca Swiss bases.

(b)

The raised platform on the sliding base to ensure the Q=Base locks into position.

(c)

The release lever to disengage the sliding block from the spindle.



The Castel-M attached directly to the front standard and sliding block of the CASTBAL-PRO bellows and the Schneider Kreuznach Pyrite f/4.5/90. This setup is ideal for product photography:

direction. The main sliding base incorporates a locking lever when disengaged allows positioning of the base freehand. When in place, locking the lever engages the base to the spindle again.

The underside of the long dovetail Arca style guide has dual tripod 1/4 and 3/8 mounts. The rail can be connected directly to the tripod or to a copying unit if necessary. There is also a milled cut-out for a safety pin and stop screws to keep the sliding block within the confines of the spindle. The Castel-M can also be mounted directly to the BALPRO and BAL-F bellows systems for complete versatility and obtaining greater reproduction ratios with a wide variety of lenses. The Castel-M is also ideal for product photography. It can be equipped with the CASTBAL-PRO bellows attachment, transforming it into a fully-fledged technical camera. In this configuration, the

stacking steps are performed by moving the bellows rear standard, while the lens standard remains fixed. Employing this approach means the position of the lens does not change in relation to the subject, which can be important in certain types of product photography in controlling unwanted reflections, especially in jewellery and other similar types of subjects.

(Right)

The Castel-M can be used in a wide range of photography situations when you need to focus stack to extend the zone of sharpness or to control the level of background focus. Or in commercial photography especially jewellery and related products.

(Below)

Shooting at wider apertures avoids diffraction. With larger subjects and the incremental selector set to X allows the photographer complete control over the stepping distances between shots.



Image © Andreas Marx.



Image © Andreas Marx.





*(Previous page)
Geranium species*

Focus stacking is the only method of being able to hold all of the stamens in focus of this tiny flower.

The Castel-M is ideally suited for focus stacking in the field. I find it quick to set up and operate with any lens.

(Left)

The Castel-M with the Laowa 15mm 2.5X-5X f/2.8 ultra macro lens.

IN THE FIELD

The ultimate test for any piece of equipment is how it performs, and whether it meets the expectations of what it claims to deliver. Like any new piece of kit, it takes a little time to acquaint yourself with the settings and how and when to use it. If you routinely use focus stacking in your photography and don't use or can't justify the price of an electronic rail, then look no further than the Castel-M. There is no other rail quite like this one currently available. Attaching the camera assembly to the rail is straightforward. You will need an Arca Swiss clamping plate. I suggest using one of the Novoflex QPL plates as the milling and angulation of the dovetail is precise ensuring that the camera is held firmly with no play whatsoever. One point to bear in mind is that all Arca-style plates differ slightly between manufacturers. The angle on the dovetail and design may not

be as secure as those designed by each manufacturer for their own products.

I have found the Castel-M straightforward to use in the field. I have tested it on a range of different subjects with excellent results. The rail is quick to attach to your camera and tripod head. It's an ideal size and weight, easily carried and fits neatly into smaller backpacks. The easiest and most efficient way to use the rail is attached to a focusing rail for quick positioning and fine-tuning especially if you are working at high reproduction ratios. But an additional rail is not essential in my opinion. The elongated dovetail allows for easy placement of the rail close to the desired starting point. Unlocking the lever on the sliding block will let you make fine adjustments to your starting position. When shooting at higher magnifications, you can rotate the focus wheel in either direction to



*Slime Mould
Ceratiomyxa fruticulosa*

I found this tiny slime mould growing on a decaying branch. A total of 70 images were used to complete the composite image.

*Nikon Z 9 Laowa f2.8
2.5-5X ultra macro.
Magnification ratio 3X.
Supported on the PRO75
and MagicBall head.*

fine-tune the focus point before commencing photography.

Having used the Castel-M and Castel Micro in the field on a range of different subjects I can say the results from the Castel-M are impressive and certainly on par with those from the Castel Micro up to the magnification range of 5:1. The Castel Micro is Novoflex's premier electronic focusing rail which is capable of much greater reproduction ratios and can be used with other specialised equipment which justifies its higher price. The diffraction calculation based on an aperture of $f/4$ quoted by Novoflex is the same in both the Castel-M and Castel Micro ensuring both rails are on equal standing within the designated magnification range. The manual rail is obviously quicker to place and set up while the electronic rail requires a little

more time to prepare, but much quicker in capturing the sequence since you do not have to touch the camera assembly in-between shots. Both have their respective niches within the macro field.

The design of the Castel-M ensures that the most vulnerable parts are enclosed making it safe to use in the field irrespective of the weather conditions. There is no routine maintenance required and the rail should function flawlessly for many years to come. I was also keen to see if there was any transfer of vibration during the rotation of the wheel to other parts of the rail or camera assembly, but that is not the case. The whole action of rotation of the focus wheel is extremely smooth, solid, and nicely balanced. It was a pleasure to use this rail in different locations and terrains. I have tested the rail with several different lenses



*Scarlet Elf Cup
Sarcoscypha austriaca*

An attractive cup fungi common found in wet woodland. Being able to shoot at wider apertures avoids diffraction using the lenses sweet spot and lower ISO values.

Nikon Z 9 with the Z 105mm Z MC f/2.8 VRS. A total of 29 images were used to make the final composite photo using the Castel-M. Supported on the PRO75 and MagicBall head.

and camera bodies. I find the Laowa 25mm $f/2.8$ 2.5-5X the ideal lens to get the best from the rail within the reproduction range. When I need to focus stack images below 1:1 I still prefer to use the rail rather than focus ring rotation for several reasons. In-camera focus stacking is not completely reliable in most cases. It is also utilising autofocus which is not ideal. In addition, the magnification is changing with each rotation although the software compensates for this up to a point. Using the rail with the lens in manual gives you complete control. It's the focus point that changes, not the magnification as you progress through the image sequence. I find the manual approach produces fewer artefacts and cleaner results at any given magnification. When photographing below 1:1 I use the rail frequently with the Nikon Z

105mm macro with the incremental lever set to X, this gives me the freedom to control the degree of movement between each shot using the engraved markings on the focus wheel. The beauty of this rail is you can customise it to suit the way you normally prefer to work. At lower magnifications when the click stop is engaged you may find shooting an image every second or third click stop is adequate. You can carry out a few simple tests at typical magnifications below 1:1 that will allow you to establish a routine procedure when working at lower reproduction ratios.

The Castel-M can be used in combination with the BALPRO and BAL-F bellows systems with a wide selection of specialist lenses including the Schneider Kreuznach Pyrite $f/4.5/90$ mm which is a perfect combination for product



*Black Eyed Susan
Rudbeckia hirta*

A striking flower found mainly in early summer.

Most of the subject is on a flat plane making it easier to focus stack. A total of 20 images were used to create the composite photo using the Castel-M.

Nikon Z 9, Z 105mm Z MC f/2.8 VRS macro. Supported on the PRO75 and MagicBall tripod head.

photography. My preferred choice in most cases for field photography is the Z MC105mm *f*/2.8 VR-S and the Laowa 25mm *f*/2.8 2.5-5X macros on my Z 9. The Laowa is light and shooting images in the region of 2.5-3.5X in the field is very straightforward. The rail can be attached to the CASTELBAL-PRO by attaching the front standard to the rail and camera standard of the bellows to the sliding block of the Castel-M. In this configuration, the lens remains static and does not change in relation to the subject. The stacking sequence is carried out by moving the camera standard on the bellows. This approach has more relevance in product photography and in situations where the movement of the lens may give rise to reflections.

To get the best from any piece of equipment especially when shooting high-end macro, you must have an excellent head and a stable tripod; this is essential in my

opinion to achieving continuity in your results. Mounting a high-quality rail and camera on an inadequate head or tripod will affect the final result. A 30-image stack will require you to touch the camera assembly each time to complete the series of photos for the composite. I can't stress the importance of having a solid setup, you don't want it to compromise your work.

Another point worth mentioning is the durability of the anodising on the rail. It is very scratch resistant. The majority of manufacturers tend to opt for black or grey, but I usually find within a short period of time scratches begin to appear as a result of general use which is an accepted fact. During my few months using the prototype rail out in different terrain and weather conditions no visible signs of scratches etc. were detected; this is similar in my experience with all of the Novoflex products I own or use.



*Jelly Ear Auricularia
auricula-judae*

Whether you are shooting below 1:1 or above the Castel-M can adapt to your preferred method of capture. I wanted to maintain the zone of sharpness right through the fungus to ensure I could maintain focus on the tiny little ladybird at rest inside.

Nikon Z 9, Z 105mm Z MC f/2.8 VRS macro. Supported on the PRO75 and MagicBall head.

A FINAL WORD

There is no doubt the Castel-M is another excellent innovation from Novoflex. It more than measures up to the professional standards that you would expect from such a well-designed and crafted product. The solid construction of the rail and its parts indicate that it should give many years of trouble-free -service without any issues. I have no doubt this rail will prove popular among the macro fraternity for its ease of use and most importantly, the results it can deliver. Not everyone can justify the cost of an electronic rail. The fact that there is now a credible alternative capable of delivering comparable results to an electronic rail will make it a popular choice among macro photographers engaged in other photographic sectors.

The uniqueness of the Castel-M warrants the price tag of £599.00 (€649.00) in my opinion. It surpasses any other manual rail

that I have owned, seen or tested. It is well worth going the extra mile for a quality product such as this. Having purchased other rails over the years, this one outperforms all of them for many of the reasons already stated. I have bought many accessories and other specialised equipment from Novoflex and have never been disappointed with the performance of any of their products. Buying into a system where every accessory works seamlessly with another is the way to go in my opinion. You get that continuity and perfect integration between components which, for me, is worth that little bit extra for peace of mind.

The innovation behind this rail is what sets it in a class of its own. No other equipment manufacturer has developed anything remotely like it. I have no doubt it will generate a lot of interest among other competing manufacturers. Although Novoflex is renowned for creative innovation

and doing things their own way. Thinking outside the box, rather than adopting the conventional approach is what defines innovation in my opinion. The engineers at Novoflex in this case

have ventured yet again to be different as they often do. The result is a top-of-the-range product that sets it apart from the rest.

Acknowledgements

I would like to express my sincere thanks to Martin Grahl General Manager of sales and distribution at Novoflex, Memmingen, Germany for answering many questions and for the use of the Castel-M rail. Also, Andreas Marx Master Photographer and Head of the Technical Division at Novoflex for permission to use his product images.

Some of the product images in this review are under copyright from Novoflex and Andreas Marx and require their permission before use.

Further information on the Novoflex products relating to this review can be obtained at:



www.novoflex.de



Robert Thompson is a professional freelance natural history photographer, author and conservationist. He is a Fellow of the Royal Photographic Society and the Irish Photographic Federation; an acclaimed macro specialist in the UK, and the author of a number of books on natural history and photography. His work is widely published in the UK, Ireland and internationally; with numerous photographic credits in a variety of publications including, Nikon Pro, Nikon NPS, Nikon Owner and other media sources.

As an active conservationist, he has worked on many high-profile natural history projects in Ireland. He has had several solo exhibitions of his work and is a frequent traveller; running workshops in some of the most picturesque alpine regions of Europe and at many of Ireland's most iconic locations.

www.robertthompsonphotography.com



NOVOFLEX NOVOFLEX Präzisionstechnik GmbH
Brahmsstr. 7
D-87700 Memmingen
Germany

Tel.: +49 8331 88888
Fax: +49 8331 47174
Email: mail@novoflex.de

United Kingdom
Speed Graphic Mail Order Ltd
Unit 9A Oakhanger
Farm Business Park
Oakhanger
Bordon GU35 9JA
Tel: +44 1420 560 066
email: sales@speedgraphic.co.uk
www.speedgraphic.co.uk

USA
MAC Group
75 Virginia Road
North White Plains
NY 10603
Tel: +1 914 347 3300
Fax: +1 914 347 3309
email: info@macgroupus.com
www.macgroupus.com

Canada
Red Raven Marketing
74 Marietta St.
Uxbridge, Ontario
L9P 1J5
Tel: +1 905 852 4106
Fax: +1 905 852 4106
eMail: info@redravenphoto.com
www.redravenphoto.com

Castel-M Gallery One

Dead Moll's Fingers Xylaria longipes

I found these tiny developing fungi on the underside of a decaying log.

Z 9, Laowa 25mm 2.5-5X ultra macro lens. Magnification, 2.5X. Number of images in stack, 42. ISO 400, supported on the PRO75 and MagicBall head.



Slime Mould Arcyria species

A tiny specimen only 3mm in height growing among the mycelium threads.

Z 9, Laowa 25mm 2.5-5X ultra Macro lens. Magnification, 4X. Number of images in stack, 72. ISO 400, supported on the PRO75 and MagicBall head.



Pale Jelly Ear Auricularia auricula-judae var. lactea

A small group of fungi that differ from the normal colour form which is brown. These specimens lack the brown pigmentation and are white.

Z 9, Z MC 105mm VR.S macro. Magnification, 0.5X, Number of images in stack, 41. ISO 200, supported on the PRO75 and MagicBall head.



Castel-M Gallery Two



(top left) *Bleeding Fairy Helmet*
Mycena haematopus Z 9, Laowa
25mm 2.5-5X ultra macro lens.
Magnification, 2.5X. Number of
images in stack, 58 ISO 400.

(top right) *Xylaria hypoxyylon* with
orange *Hypocreopsis xylariicola* on
the surface. Z 9, Laowa 25mm 2.5-
5X ultra macro lens. Magnification,
3.5X. Number of images in stack, 69,
ISO 400

(left) Lichen *Physcia leptalea* Z 9, Z
MC 105mm VR.S macro lens.
Magnification, 0.75X. Number of
images in stack, 41, ISO 200.

Castel-M Gallery Three



(Top left) *Snowy Disco Lachnum virgineum* These tiny fungi are about 1.5mm in size. Z 9, Laowa 25mm 2.5-5X ultra macro. Magnification, 3.5X. Number of images in stack, 72, ISO 400.

(Top right) *Fungi-covered Metatrachia floriformis* Z 9, Laowa 25mm 2.5-5X Ultra Macro. Magnification, 4X, Number of images in stack, 96, ISO 400.

Developing Millipede in chamber. Z 9, Laowa 25mm 2.5-5X ultra macro lens. Magnification, 2.5X, Number of images in stack, 44, ISO 400.

Castel-M Gallery Four



Small Stagshorn Calocera cornea
Tiny fungi growing in a crevice of
a decaying tree stump.

Z 9, Z MC 105mm VR.S macro.
Magnification, 1X. Number of
images in stack, 24, ISO 400.

The Blusher Amanita rubescens
and beech mast seed pod.

The fallen seed pod had embedded
itself into the top of the fungal cap.

Z 9, Z MC 105mm VR.S macro.
Magnification, 0.5X. Number of
images in stack, 54, ISO 200.



Tiny Mycena species growing on
moss branches,

Z 9, Laowa 25mm 2.5-5X ultra
macro. Magnification, factor 3X.
Number of images in stack, 49.
ISO 400.

Castel-M Gallery Five



Common Centipede Lithobius forficatus

Z 9, Z MC 105mm VR.S macro lens .
Magnification, 0.5X. Number of images in
stack, 16, ISO 400.



*Penicillium Bread Mould Extreme close-up of
the mould that appears on bread when left.*

Z 9, Z MC 105mm VR.S macro lens.
Magnification, factor 0.5X. Number of
images in stack, 59, ISO 400.



*Small Crust Fungus.
Schizopora species. Tiny
developing crust about 9mm
in total across.*

Z 9, Laowa 25mm 2.5-5X
ultra macro. Magnification,
3.5X. Number of images in
stack, 73, ISO 800.

Castel-M Gallery Six



Frosted Grass Always a good test for defining detail. Z 9, Z MC 105mm VR.S macro lens. Magnification, 0.5X, Number of images in stack, 15, ISO 200.

Fungal Mycelium network fibres. Tiny little fibres that form part of the mycorrhizal network connecting plants to transfer water etc. Z 9, Laowa 25mm 2.5-5X ultra macro lens. Magnification, 2.5X. Number of images in stack, 41, ISO 400.

Golden Bootleg Phaeolepiota aurea Large striking species. I wanted to keep the background diffused and chose a wide aperture. Z 9, Z MC 105mm VR.S macro lens. Magnification, 0.3X. Number of images in stack, 11, ISO 200.



Castel-M Gallery Seven

Below is a series of product photos taken by Andreas Marx demonstrating the wide diversity and the many applications that the Castel-M is suited to. Used in combination with the bellows and Schneider Kreuznach Pyrite f/4.5/90 les make an ideal setup for product photography. Images © Andreas Marx.





www.robertthompsonphotography.com